

Compounding technology For dilution of carbon black masterbatch

Pursuit of excellent dispersion

1. Outline

High density polyethylene (HDPE) used for water pipes or automobile gasoline tanks generally contains carbon black powders approx. 2.5wt% to improve weather resistance of the products. However, fine powders such as carbon black present significant handling problems or pollution of the work places. So recently, masterbatch which contains carbon black powders with high concentration and good dispersion are preferably used in many compounding processes.

It is relatively easy to disperse carbon black masterbatch into the base polymer. The most important point for this kind of compounding is to minimize the equipment for cost reduction. And to optimize the equipment, it is necessary to know the actual dispersion behavior inside the extruder.

We are reporting here the test results to observe dilution process of carbon black masterbatch in our twin screw extruder TEX65 α II.

2. Test equipment and conditions

- 1) Material : HDPE pellets (MI=0.04) + 6.25wt% carbon black masterbatch
(concentration of carbon black : 40wt%)
- 2) Extruder : TEX65 α II-24AW-V
- 3) Screw elements for mixing : Forward kneading block \times 5 sets + Reverse flight

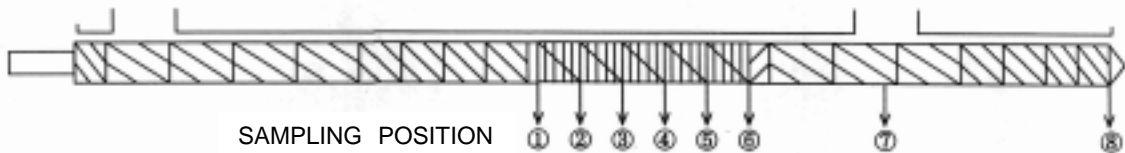

Fig. 1 Screw configuration

- 4) Sampling valve : Attached to extruder cylinders for sampling melt polymer during compounding



Photo 1 Sampling valve

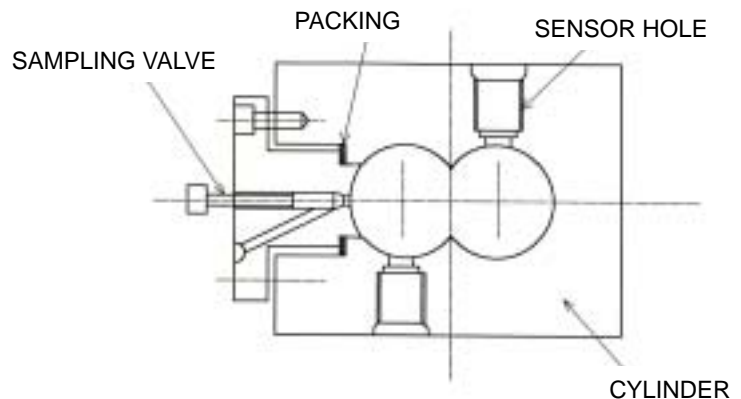

Fig. 2 Structure of sampling valve

- 5) Tip clearance of kneading disks : Standard, $\times 3$, $\times 6$
 6) Operating conditions : Throughput 210 kg/h
 Screw speed 250 rpm
 Cylinder temp. 200°C

3. Test results, analysis and conclusion

Photo 2 shows that the dispersion of carbon black masterbatch progresses as the polymer flows toward downstream in all three tip clearance conditions. We can also see that the larger the tip clearance is, the faster the dispersion of carbon black masterbatch progresses.

This result indicates that we can obtain optimal dispersion of carbon black masterbatch by optimizing the tip clearance so as to maximize the product of the ratio of polymer passing through the tip clearance to the whole flow rate multiplied by the shear rate to carbon black masterbatch.

We can apply these data in specifying the optimum screw configuration and operation conditions for the dilution of carbon black masterbatch and other compounding processes. Actually, we have provided a lot of compounding extruders to the customer with the kneading blocks of our original disk combinations and optimum tip clearance.

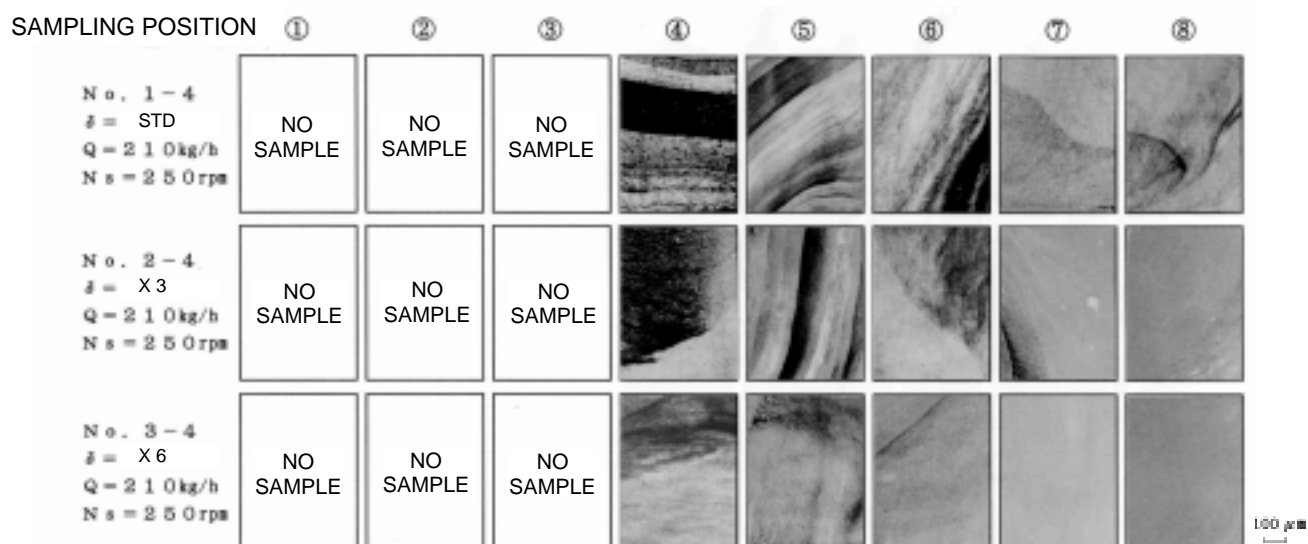

Photo 2 Observation result

4. Afterword

In the dilution process of carbon black masterbatch, it is very important technique to optimize the tip clearance of the mixing section of extruder screws.

We have introduced here the study for dilution of carbon black masterbatch, which is a part of our compounding technology. A great variety of screw configurations are available now and we are ready to propose you the best one suitable for your material and process.

For more information ; THE JAPAN STEEL WORKS, LTD.

Sales Dept./Tokyo Hibiya Mitsui Bldg., 1-2, Yurakucho 1-chome, Chiyoda-ku, Tokyo, Japan 100-8456
 Phone : +81-3-3501-6134 Fax : +81-3-3595-4621

Hiroshima Plant 6-1, Funakoshi-minami 1-chome, Aki-ku, Hiroshima-city, Japan 736-8602
 Plastics Machinery Dept.
 Phone : +81-82-822-5515 Fax : +81-82-824-1512

Home page address : <http://www.jsw.co.jp/>